

SRFT

Sri Ragavendra Fab Tech

Engineering Solutions



SRFT

Reach Us:

261, 10th Street, Sidco Industrial Estate,
(Sector 2) Ambattur, Chennai – 600 098.

Mobile: +91 98408 20559 | Email: ragavendrafabtech@gmail.com |

Website: www.srft.in



COMPANY PROFILE

We, Sri Ragavendra Fab Tech, were established in 2015. We are one of the market Leading manufacturer of SPM, conveyor Automation, Material Handling Equipment and Accessories This is a new startup company, and we are having Hands-on experience in **SPM, conveyor, and Material Handling Equipment** for Above 9 years. We will have a good Infrastructure and equipment, Helps us to maximize our Production and standardization Quality. Our product range comprises Belt Conveyors, Chain Conveyors, Roller conveyors, slide conveyors, spiral roller conveyors, and several other products.

Our Services:

Besides, we are a leading service provider of Fabrication services such as dairy and beverage piping fabrication work, heavy structure fabrication service, jigs and fixtures fabrication service, SS Fabrication service, and several other services. These presented services are very satisfactory and easy to obtain from us with our team of diligent professionals. These offered services are more satisfying and obtainable as per needs and requirements.

We have a team of skilled professionals who hold expertise in the relevant field. We are expertise in:

All kinds of Fabrication works

- Metal-Fabrications
- Aluminium Fabrications
- Steel Fabrications
- Vessel Fabrications
- Mig Welding
- Stud Welding
- Projection Spot Welding
- Water Jet Cutting
- Erection
- Laser Marking
- Laser Cutting
- Powder Coating

We offer the best products and services to industrial consumers. Patrons may easily obtain these from us as per their needs and requirements. Besides this, professionals maintain long-term relationships with consumers to meet their requirements.

PRODUCTS & SERVICES

MACHINING PRODUCTS



Supplies to Ashok Leyland and TVS Group

We specialize in producing high-quality parts made to order, using state-of-the-art CNC machines and expert craftsmanship. High-quality components range includes bearings, gears, shafts, pulleys, clutches, etc.

Services:

- CNC Milling
- CNC Turning
- CNC Grinding
- CNC Drilling
- CNC Tapping



Capabilities:

- Precision parts made to exact specifications
- High-volume production runs
- Fast turnaround times
- Competitive pricing



PRODUCTS & SERVICES

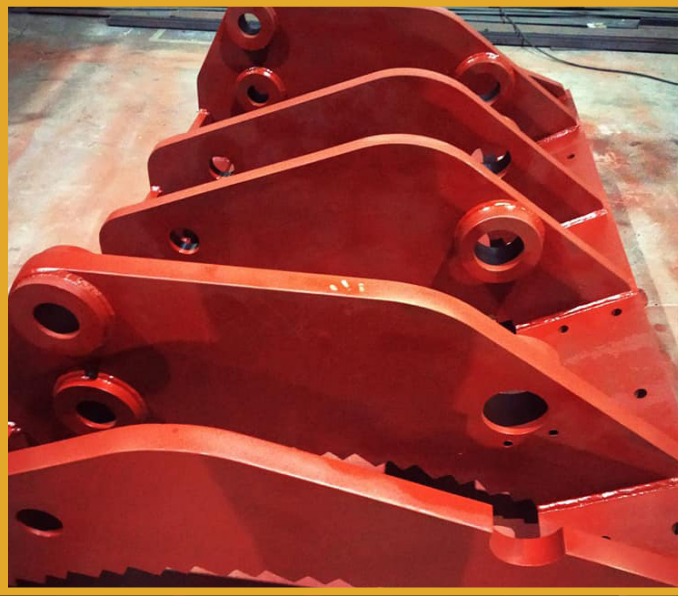

HEAVY DUTY CONVEYOR MAIN LINKAGE COLE MINE

USAGE:

The main linkage refers to the primary chain or belt that connects the conveyor's drive system to the tail pulley, enabling the movement of coal along the conveyor belt.

Key Components: 1. Chain or Belt, 2. Drive System, 3. Tail Pulley

Coal Mine Usage: 1. Coal Transportation, 2. Material Handling, 3. High-Capacity Operations



Main Frame

The main frame is the structural backbone of the conveyor, providing the necessary support and stability for the conveyor belt, drive system, and other components.

Heavy Conveyor Features:

1. High-Capacity Operation,
2. Heavy-Duty Construction,
3. Customizable Design

PRODUCTS & SERVICES



CONVEYOR BELT HEIGHT ADJUSTER UNIT

A conveyor belt height adjuster unit is a mechanism used to adjust the height of a conveyor belt in various industrial applications, including cement factories, mining, and material handling.

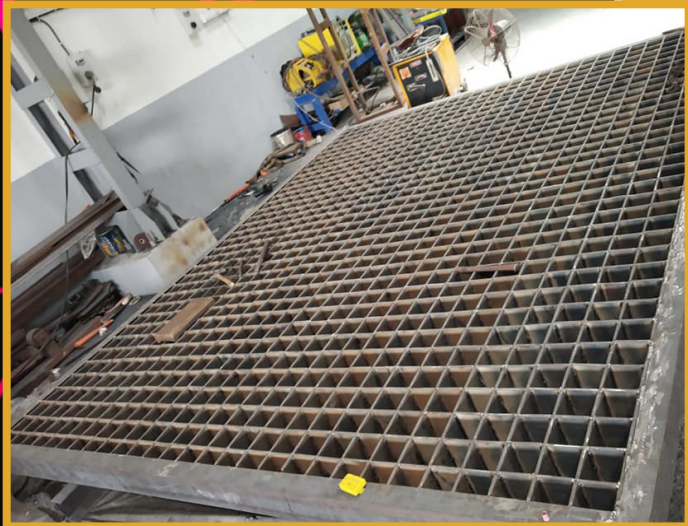

CEMENT FACTORY MEZZANINE FLOOR STRUCTURE

A mezzanine floor structure in a cement factory is an intermediate floor level between the main floors, used for various purposes such as:

- 1. Storage:** Storing equipment, spare parts, or materials.
- 2. Maintenance Access:** Providing access for maintenance and repairs.
- 3. Work Platforms:** Creating work areas for personnel.
- 4. Pipe Racks:** Supporting pipes and ducts.

Design Considerations: 1. Load Capacity, 2. Clearance, 3. Accessibility, 4. Safety, 5. Corrosion Protection

PRODUCTS & SERVICES

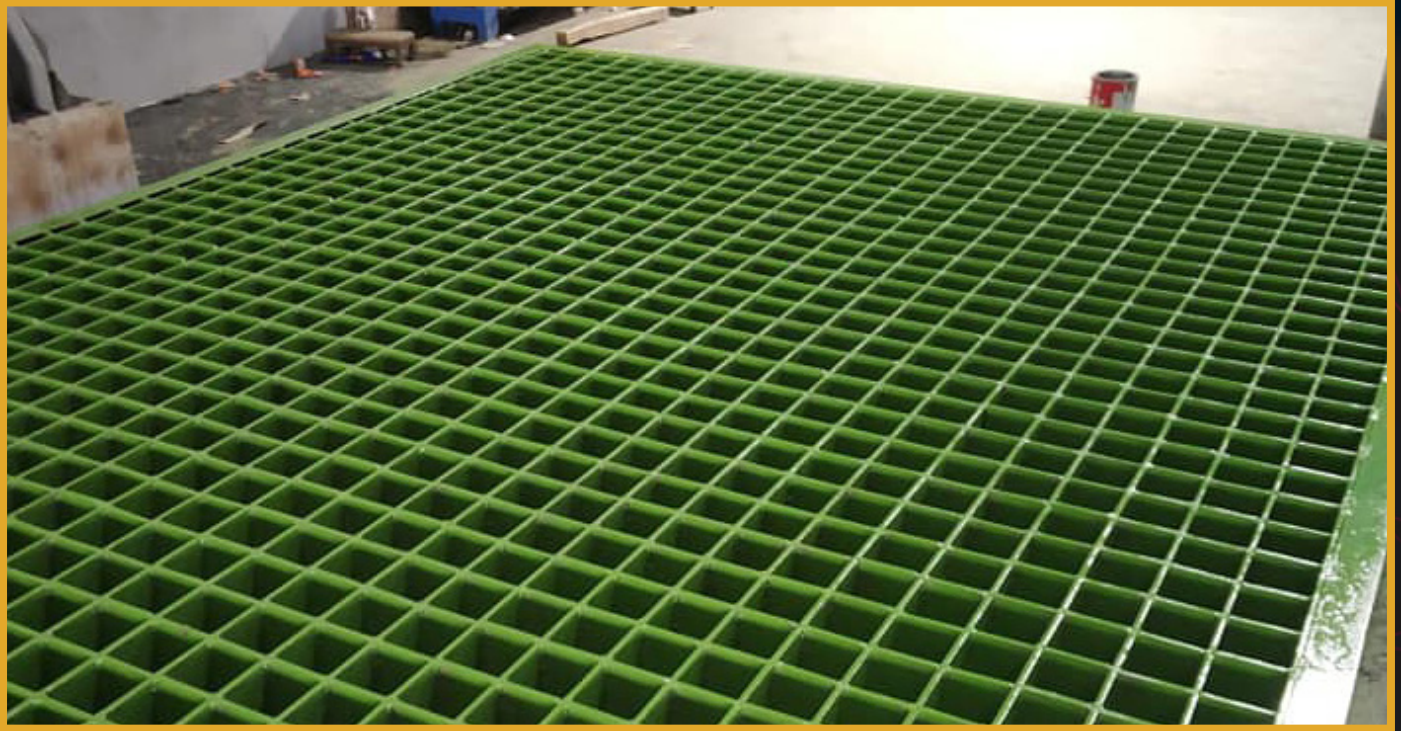

SPM MACHINE BASE STRUCTURE FOR JK FENNER GROUP OF COMPANIES

An SPM (Special Purpose Machine) base structure refers to the foundation or base frame that supports the machine's operation.

Purpose: 1. Vibration Reduction,
2. Structural Integrity,
3. Alignment and Leveling

Design Considerations:
1. Load Capacity, 2. Material Selection, 3. Vibration Damping,
4. Leveling and Alignment,
5. Maintenance Access

PRODUCTS & SERVICES

CONVEYOR



TIMING BELT CONVEYOR

A timing belt conveyor is a type of conveyor system that uses a toothed belt to transport materials.

Advantages: 1. Precise Control, 2. High Speeds, 3. Low Maintenance, 4. Quiet Operation, 5. Versatility

Benefits: 1. Increased Efficiency, 2. Improved Accuracy, 3. Reduced Downtime, 4. Enhanced Productivity, 5. Customization



UNLOADING AND LOADING CONVEYOR

An unloading and loading conveyor is a type of conveyor system designed for efficient loading and unloading of materials, products, or goods.

Types: 1. Belt Conveyors, 2. Chain Conveyors, 3. Roller Conveyors, 4. Vibrating Conveyors

Applications: 1. Warehousing and Distribution, 2. Shipping and Receiving, 3. Manufacturing, 4. Agriculture

PRODUCTS & SERVICES

PART RECEIVER CONVEYOR FOR AUTOMOBILE INDUSTRY

A part receiver conveyor for the automobile industry is a specialized conveyor system designed to receive, transport, and store automotive parts, such as:

1. Engine components
2. Transmission parts
3. Body panels
4. Interior components

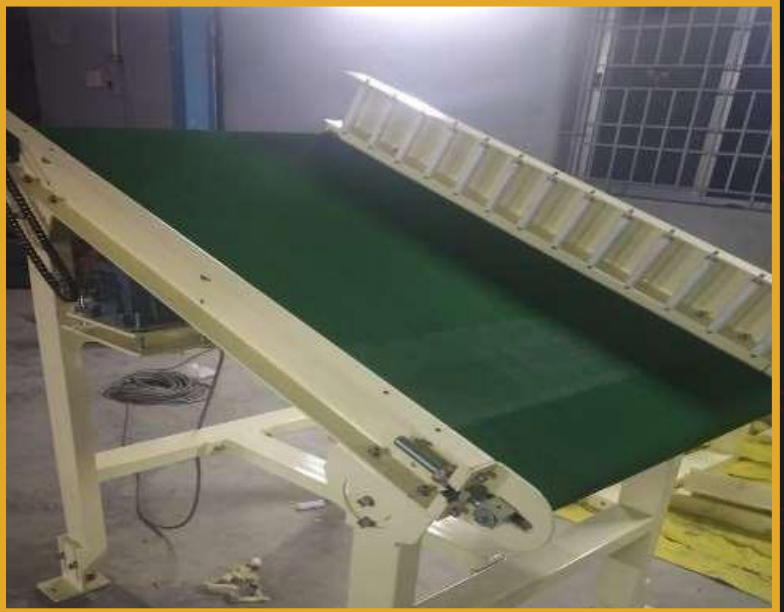

RUBBER BELT **CONVEYOR FOR** **COLE MINE**

INDUSTRY: A rubber belt conveyor for the coal mine industry is a type of conveyor system designed to transport coal, minerals, and other bulk materials in a safe and efficient manner.



PRODUCTS & SERVICES

CONVEYOR





IDLER FRAME WITH IDLER ROLLERS

An idler frame with idler rollers is a crucial component of a conveyor system, responsible for supporting and guiding the conveyor belt.

Idler Frame:

1. Structural Component: A rigid frame that holds the idler rollers in place.
2. Material: Typically made from steel, aluminum, or other durable materials.
3. Design: Customized to fit specific conveyor systems and applications.

Idler Rollers:

1. Supportive Function: Idler rollers support the conveyor belt and maintain its shape.
2. Rotation: Idler rollers rotate as the belt moves, reducing friction and wear.
3. Types: Various types, including:
 - Troughing idlers (center and wing idlers)
 - Return idlers
 - Impact idlers
 - Transition idlers

Benefits:

1. Smooth Belt Movement,
2. Reduced Wear and Tear,
3. Improved Tracking,
4. Increased Efficiency

PRODUCTS & SERVICES



30 METER BELT CONVEYOR FOR CEMENT FACTORY

PRODUCTS & SERVICES

Idlers are components used in various industries to serve several purposes. Here is some common usage of idlers, 1. Conveyor Systems, 2. Machinery, 3. Tensioning, 4. Guidance, 5. Support, 6. Alignment, 7. Vibration Reduction, 8. Load Distribution and more

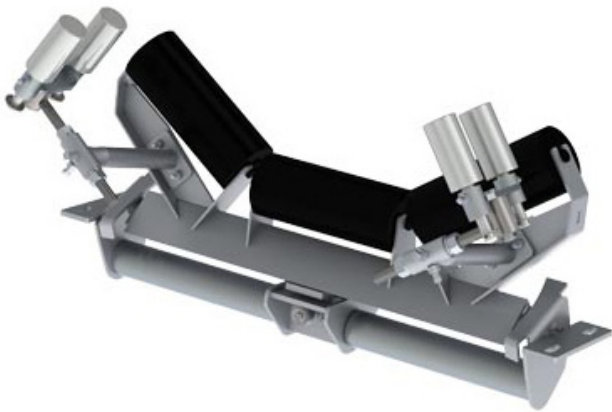

PRODUCTS & SERVICES



CONVEYOR SKIRT BOX CLOSURE

A conveyor skirt box closure is a component used to seal the gap between the conveyor belt and the skirt board, preventing material spillage and dust emission.

Benefits: 1. Reduced Material Loss, 2. Improved Safety, 3. Increased Efficiency, 4. Environmental Protection

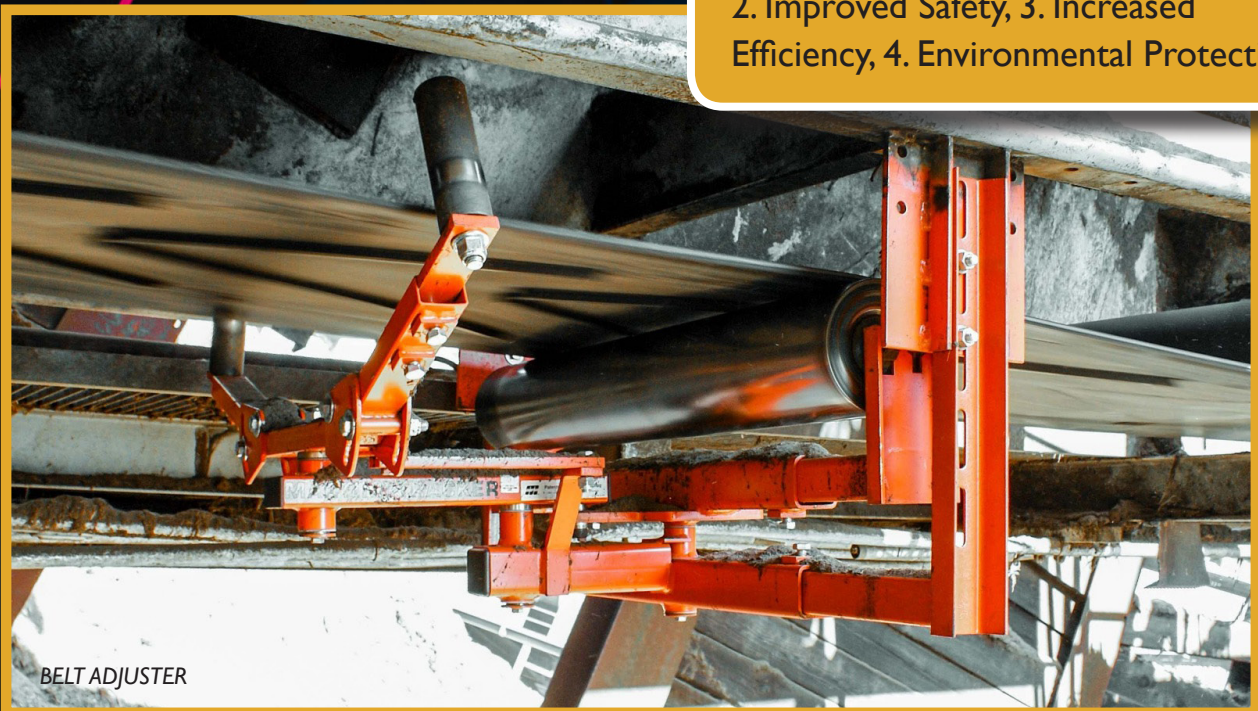

BELT ADJUSTER

PRODUCTS & SERVICES

STEEL IDLERS

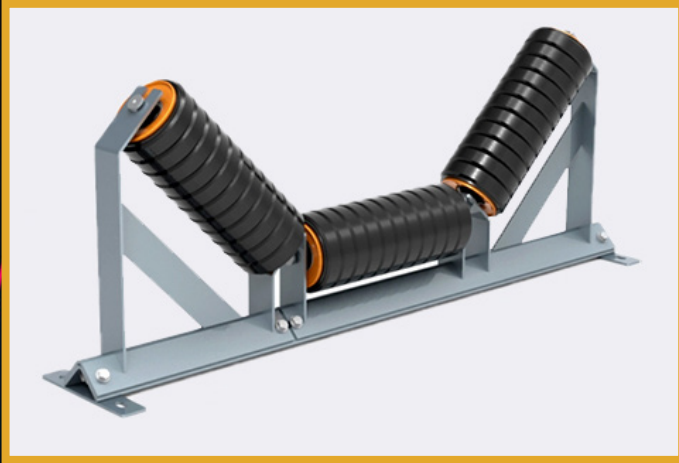

IDLER FRAMES

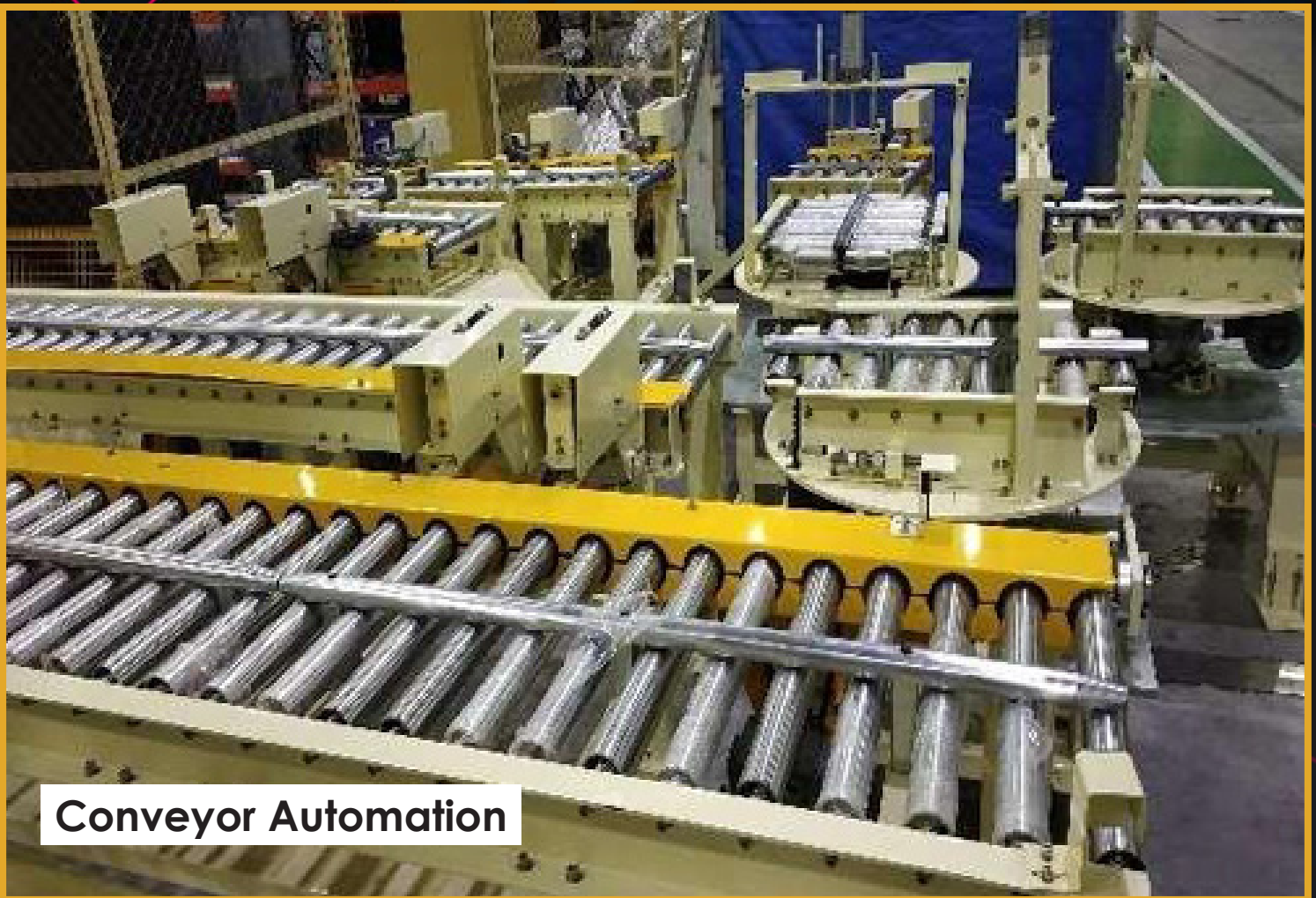
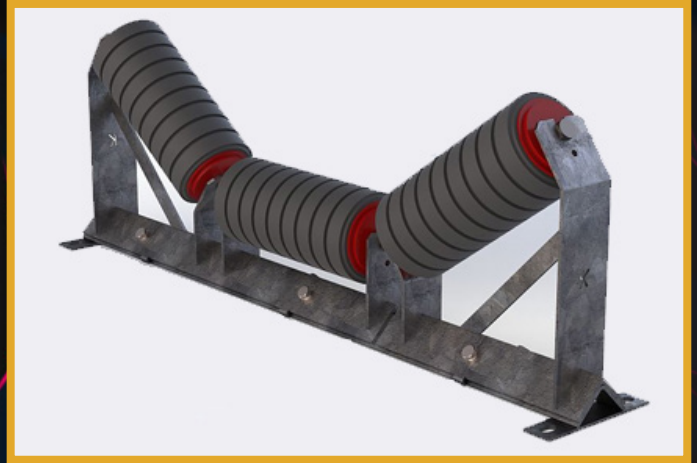

Conveyor Automation

PRODUCTS & SERVICES



IMPACT BED ASSEMBLY

An impact bed assembly is a critical component of a conveyor system, designed to absorb the impact of falling materials and reduce wear on the conveyor belt.

Function: 1. Impact Absorption, 2. Belt Protection, 3. Material Containment

OUR CONVEYOR DESIGN



PRODUCTS & SERVICES

NYLON ROLLER



Rollers have various applications across different industries, including:

1. Conveyor Systems,
2. Industrial Machinery,
3. Doors and Windows,
4. Material Handling,
5. Printing and Packaging,
6. Medical Equipment,
7. Aerospace,
8. Automotive,
9. Fitness Equipment,
10. Furniture and more.



UHMW ROLLERS

UHMW (Ultra-High Molecular Weight) rollers are a type of roller used in conveyor systems, known for their exceptional durability and resistance to wear and tear.

- Benefits:**
1. Longer Lifespan,
 2. Reduced Maintenance,
 3. Increased Efficiency,
 4. Corrosion Resistance,
 5. Quiet Operation

PRODUCTS & SERVICES

LASER CUTTING



Laser cutting is a manufacturing process that uses a high-powered laser beam to cut or engrave materials such as metals, plastics, woods, and fabrics. The laser beam is directed at the material, vaporizing or melting it to create the desired shape or design.

Laser cutting offers several advantages, including:

1. Precision, 2. Speed, 3. Versatility, 4. Cleanliness, 5. Reduced material waste and more



PRODUCTS & SERVICES

LASER MARKING



Laser marking, also known as laser engraving or laser etching, is a process that uses a laser beam to mark or engrave a material. The laser beam interacts with the material, creating a permanent mark or design.

Laser marking is used in various industries, such as: 1. Aerospace, 2. Automotive, 3. Medical, 4. Electronics, 5. Fashion, 6. Food processing, 7. Pharmaceutical and more.



PRODUCTS & SERVICES

JIGS & FIXTURES

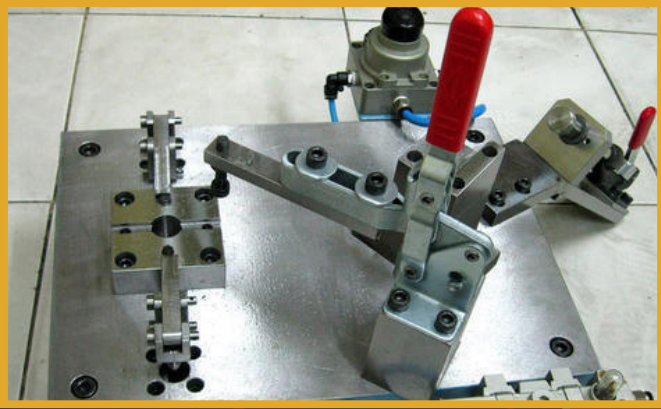

The combined purposes of jigs and fixtures include:

1. Improved accuracy and precision
2. Increased productivity and efficiency
3. Enhanced safety by reducing operator error
4. Reduced scrap and rework
5. Improved product quality and consistency
6. Simplified production processes
7. Reduced tooling costs

SEMI & AUTO PACKING MACHINE

Benefits of automatic packing machines:

1. Increased packaging speed and efficiency
2. Reduced labor costs and manual errors
3. Improved product safety and hygiene
4. Enhanced packaging consistency and quality
5. Increased productivity and throughput
6. Reduced packaging material waste
7. Easy integration with existing production lines



PRODUCTS & SERVICES

FABRICATION WORKS

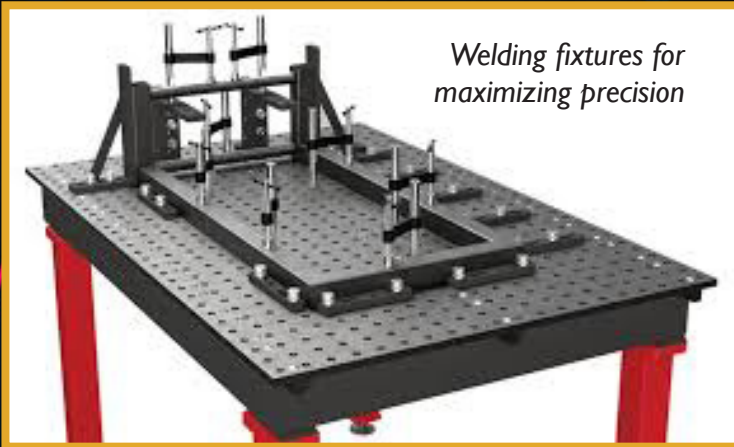

Welding fixtures for maximizing precision



Industrial ducting Chute



← Heavy Structural Fabrication

Fabricating machine → Structure



PRODUCTS & SERVICES

ROTATARY TURN TABLES



PHARMA INDUSTRY MIXER TANK



PRODUCTS & SERVICES

AUTOMACHINES



Inspection Table

An inspection table is a specialized work surface designed for inspecting, testing, and evaluating products, components, or materials.

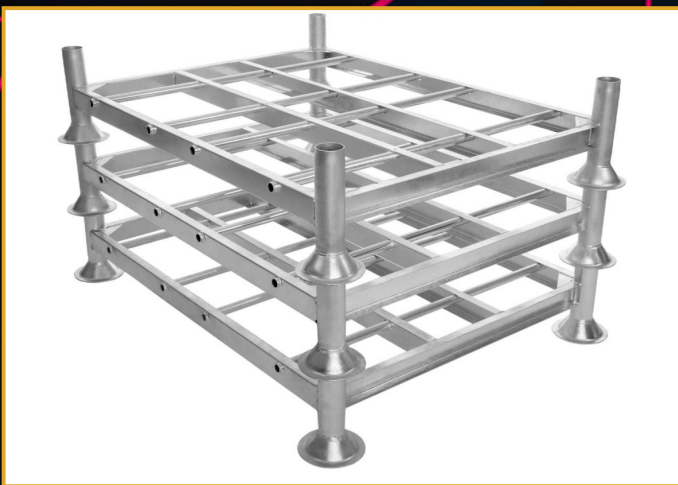

SS PALLET

An SS pallet, also known as a stainless steel pallet, is a type of pallet made from high-quality stainless steel materials.

Benefits: 1. Durability, 2. Hygiene, 3. Strength, 4. Low Maintenance, 5. Sustainability

PRODUCTS & SERVICES



HEAVY DUTY STORAGE BIN

A heavy-duty storage bin is a robust and durable container designed to store and hold large quantities of materials, products, or equipment.

Key Features: 1. Durable Construction, 2. Large Capacity, 3. Reinforced Frame, 4. Secure Lid or Door, 5. Mobility Options



↑ Metal Square tube Pallet

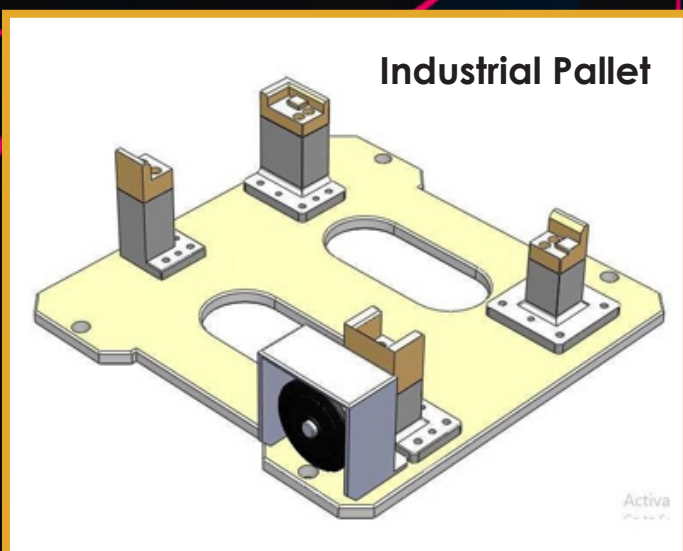

Spindle Lay Stand

PRODUCTS & SERVICES



Chennai Metro Rail Limited



VALVES - FITTINGS - REGULATORS



KIA MOTORS



Salzer Electronics Limited



BOSCH